

SUSPENSION SYSTEMS

3/21/02

'88-'98 CHEVROLET/GMC 2WD
(WITH HEAVY DUTY BRAKES)
6" SUSPENSION SYSTEM
P/N. 10-41292

INSTALLATION INSTRUCTIONS

NOTE: This system will not work on 88-91 light duty vehicles with standard brake system (Smaller rotor of 11.57" x 1"). Must use '92 or later braking system, call RCD Technical Department for upgrade requirements.

NOTE: Each Lift Kit, and options to Lift Kits, are packaged separately. Therefore installation procedures are covered in separate instructions. Familiarize yourself with each set of instructions before beginning.

Parts List

Box 1 of 6

<u>Item</u>	<u>Description</u>	<u>Qty</u>	<u>Illus.</u>
20-51292-1	Front Crossmember	1	8,12
20-51292-2	Rear Crossmember	1	12
20-68201	Hardware Pack Containing: (Front & Rear Crossmember)		
13-21950-Z	Hex Bolt, 5/8"-11 x 5-1/2" Lg. Gr. 8	2	12
13-21924-Z	Hex Bolt, 5/8"-11 x 5" Lg. Gr. 8	2	12
13-30369-Z	Flat Washer, 5/8" Hrdn.	8	12
13-10345-Z	Top Lock Nut, 5/8"-11	4	12
20-68357	Hardware Pack Containing: (Front Sway Bar)		
20-832855	Sway Bar Extension (5-1/2")	2	15
13-22743-Z	Button Head, 1/2"-13 x 3" Lg.	4	15
15-11382	Grommet	8	15
13-30668-Z	Retainer, Washer	4	15
20-68227	Hardware Pack Containing: (Bumpstops)		
15-11018	Bumpstop, Low Profile	4	8
13-30012-Z	Flat Washer, 3/8" SAE	4	8
13-10022-Z	Nyloc Nut, 3/8"-16	4	8
20-68305	Hardware Pack Containing: (Brakeline Re-locator)		
13-20447-Z	Unslot Hex, #10 x 1/2"	4	
15-10966	Clamp, Black	4	
15-11395	Wire Tie, 6"	4	
15-11447	Wire Tie, 8"	2	
15-11460	Wire Tie, 11"	2	
20-68214	Hardware Pack Containing: (Cotter Pin)		
13-90607	Cotter Pin, 1/8" x 1-1/2"	6	
13-90620	Cotter Pin, 5/32" x 1-1/2"	2	
20-68266	Hardware Pack Containing: (Brake Line Bracket)		
20-51292-12	Bracket, Brake Line (Pass.)	1	13
20-51292-13	Brake Line (Drvr.)	1	13
13-30187-Z	Flat Washer, 5/16" SAE	2	
13-10155-Z	Nyloc Nut, 5/16"-18	2	

Box 2 of 6

20-51290-5D	Front Spindles (Drvr.)	1	15
20-51290-6P	Front Spindles (Pass.)	1	15

Box 3 of 6

20-51292-16	Lateral Compression Struts, Stainless	2	14
20-51292-11	Bracket, Strut Mount-Front	2	12,14
20-51088-16	Bracket, Strut Mount-Rear	2	14
20-68162	Hardware Pack Containing: (Compression Struts)		
13-20069-Z	Hex Bolt, 1/2"-13 x 4" Lg.	4	14
13-20164-Z	Hex Bolt, 1/2"-13 x 1-1/2" Lg.	2	14
13-30034-Z	Flat Washer, 1/2" SAE	12	14
13-10038-Z	Nyloc Nut, 1/2"-13	6	14
20-68175	Hardware Pack Containing: (Compression Struts)		
15-11148	Bushing, Red	8	14
20-830918	Sleeve, 3/4" x 2-3/4" Lg.	4	14

Box 4 of 6

20-20153-1	Coil Springs (Front) 88-98 2WD	2	10
------------	--------------------------------	---	----

Box 5 of 6

20-830671	Block, Rear- 3"	2	17
13-90646	U-Bolt, 9/16"-18 x 12.5"	4	17
20-68188	Hardware Pack Containing: (U-Bolt)		
13-30330	Flat Washer, 9/16" Hrdn.	8	17
13-10423	High Nut, 9/16"-18	8	17
20-68297	Hardware Pack Containing: (Rear Brake Line)		
20-51292-14	Extension, Brake Line, Rear	1	16
20-51292-15	Extension, Bumpstop, Rear	2	18
13-20081-Z	Hex Bolt, 3/8"-16 x 1-1/4" Lg.	4	18
13-20536-Z	Hex Bolt, 5/16"-18 x 1" Lg.	2	16
13-30012-Z	Flat Washer, 3/8" SAE	8	18
13-30187-Z	Flat Washer, 5/16"	4	16
13-10022-Z	Nyloc Nut, 3/8"-16	4	18
13-10155-Z	Nyloc Nut, 5/16"-18	2	16

Box 6 of 6

BE5-6136	Shock Absorbers (Front)	2	
BE5-6137	Shock Absorbers (Rear)	2	

BEFORE YOU BEGIN

- ❑ Installation by a professional mechanic is recommended. Use of the appropriate power tools, a Chevrolet/GMC service manual and a shop hoist can greatly reduce installation time.
- ❑ Prior to installation, carefully inspect the vehicle's steering and drive train systems, paying close attention to the tie rod ends, Pitman and Idler Arms, Ball Joints and wheel bearing preload. Also check steering-to-frame and suspension-to-frame attaching points for stress cracks. The overall vehicle must be in excellent working condition; repair or replace worn parts.
- ❑ Read instructions carefully and study the illustrations before attempting installation. *Race Car Dynamics* is not responsible for damage, failure or injury resulting from improper installation or parts substitution of this kit.
- ❑ Check the parts and hardware against the parts list to assure that your kit is complete. Report any shortages to *Race Car Dynamics* at (1-619-588-4723). The parts and hardware supplied are of high grade material and must not be replaced by inferior parts or failure may result.
- ❑ Separate parts according to the areas they will be used. Placing the hardware with brackets before you begin will save installation time.
- ❑ This kit is supplied as a bolt-on assembly. Do not weld anything to the components and do not weld the components to the vehicle.
- ❑ All components in this kit come with a protective coating. Do not plate (i.e. chrome, cadmium, zinc etc.) or otherwise alter the finish in any way. This could weaken the structural strength of the components
- ❑ Secure and properly block vehicle prior to beginning installation.
- ❑ Always wear safety glasses when using power tools.
- ❑ Foot pound torque readings are listed on the Torque Specifications chart at the end of the instructions unless specifically stated in an instruction. **DO NOT USE AN IMPACT WRENCH TO TIGHTEN ANY OF THE BOLTS.**

PLEASE NOTE

- o WARNING: DO NOT USE WHEEL SPACERS
- o System will not work on 88-91 light duty vehicles with standard brake system (smaller rotor 11.57" x 1.0"). Must use 1992 or later braking system, call for technical assistance for upgrade requirements.
- o Front end realignment is necessary.
- o Speedometer recalibration is necessary if bigger tires (10% more than stock diameter) are installed.
- o Clears 33" x 12.50" tires on 15 x 8" wheels, or 35" x 12.50" with minor bumper trimming.
- o Requires wheels with a maximum of 4.5" of back spacing.
- o Headlights will have to be adjusted after install.

**The following special tools will be required for the proper removal and/or installation of this kit. The tools are available at your local Chevrolet/GMC dealer.

Ball Joint Separator Tool # J 23742

Tie Rod Puller Tool # J 6627-A

Coil Spring Removal & Installation Tool # J 23028-01

FRONT DISASSEMBLY

1) Raise the vehicle. If working without a shop hoist, support vehicle with suitable safety jack stands. Put vehicle in gear, set emergency brake and block rear wheels, in front and behind tires. Loosen Lug nuts. Lift vehicle with floor jack and place safety jack stands under frame rails, behind front wheel wells, and lower frame onto stands. Remove the front tire/wheel assemblies.

2) Remove front shock absorbers, use a wrench to hold the shock absorber stem (Top) while backing nut off from stem. Remove bottom bolts from lower control arm and pull the shock out from below.

3) Remove nut, stabilizer bolt and spacer assembly from the front lower control arm (**Illustration 1**). Rotate stabilizer bar up and out of the way.

NOTE: Be sure to remove parts from both driver and passenger side of the vehicle and keep them separate. Also check all parts for wear and damage.

4) Locate the tie rod ends. Remove nut. Attach Tie Rod Puller (J-6627A) separate the tie rod end from front spindle.

5) Locate the two caliper bolts attaching the brake caliper to front spindle (**Illustration 2**). Remove the bolts and lift caliper off brake rotor. Use a length of wire to secure brake caliper out of the way to prevent damage to the brake lines.

CAUTION: Do not allow the brake caliper to hang by the brake hose.

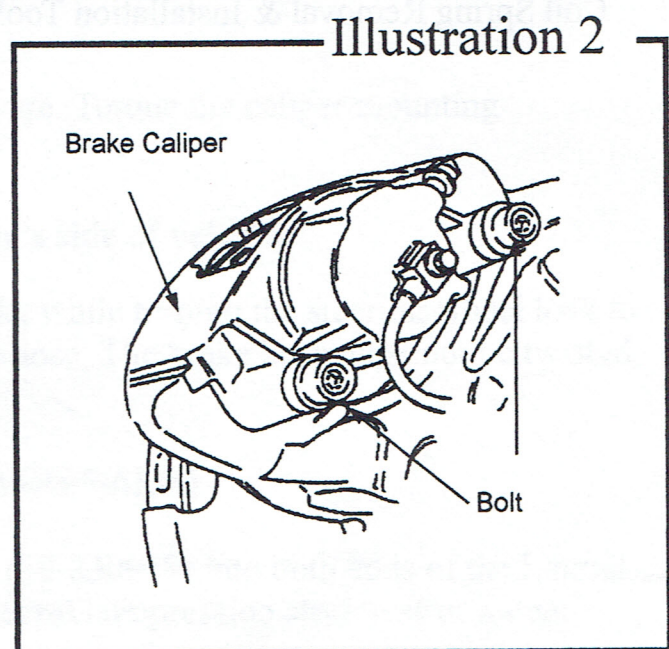
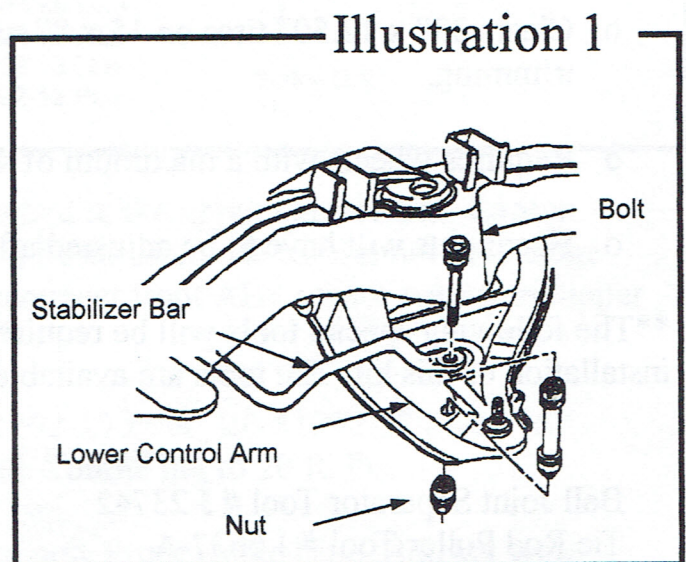
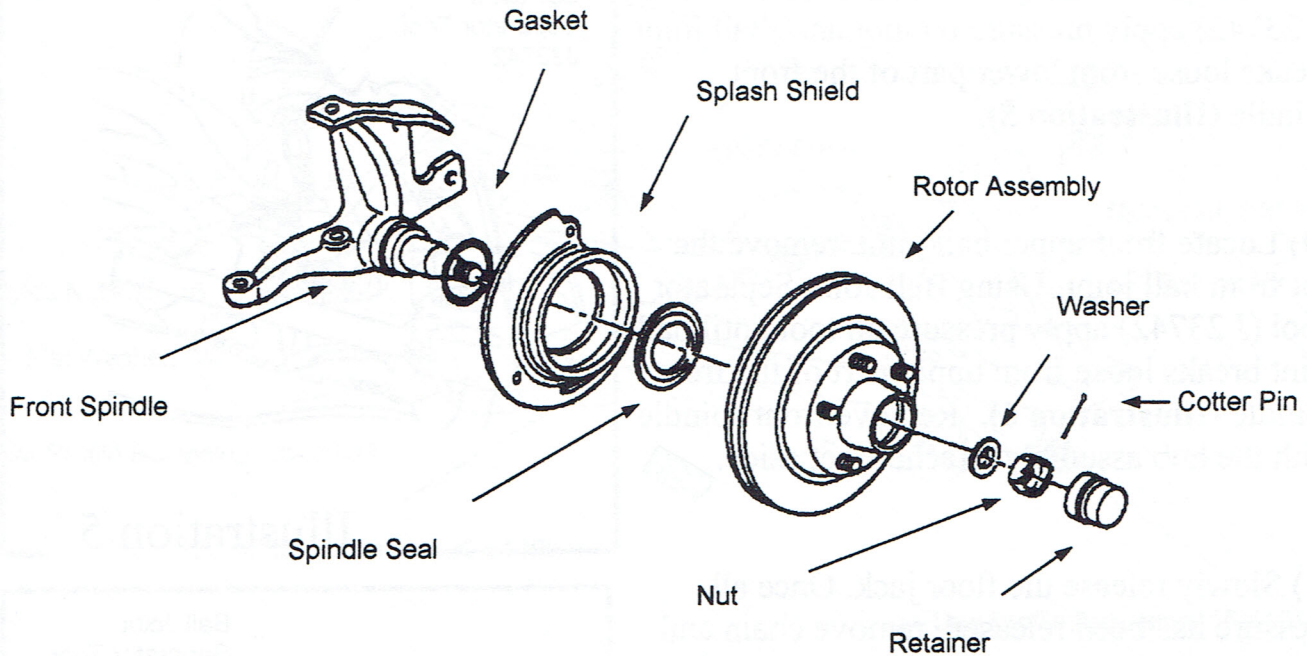

Illustration 3



6) Remove the retainer, cotter pin and hub nut from front rotor assembly and set aside (**Illustration 3**).

7) Remove three bolts securing splash shield to front spindle (**Illustration 4**).

8) Carefully remove front spindle seal. You will reuse this item.

9) Secure the front coil spring with a chain through the length of the spring and lower control arm.

10) Use a floor jack to support the front lower control arm near spring seat. Raise the jack until it just supports lower control arm.

CAUTION: Floor jack must remain under front lower control arm spring seat during disassembly to retain the spring and control arm in position or personal injury may result.

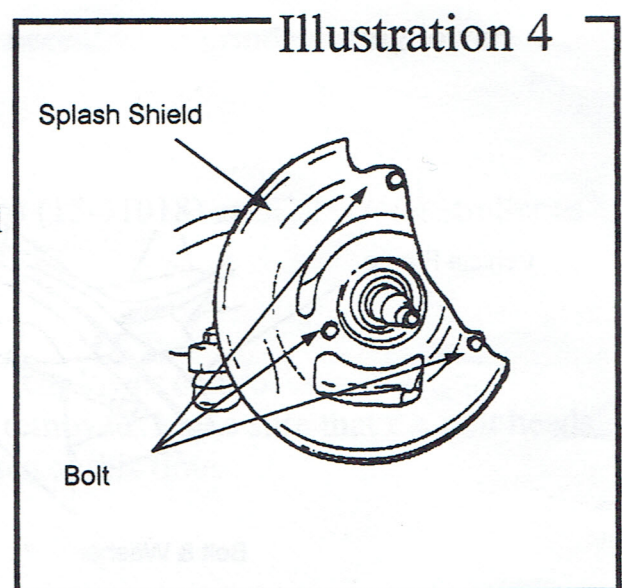

9) Locate front lower ball joint, remove the nut from ball joint. Using Ball Joint Separator Tool (J 23742) apply pressure on tool until ball joint breaks loose from lower part of the front spindle (Illustration 5).

10) Locate front upper ball joint, remove the nut from ball joint. Using Ball Joint Separator Tool (J 23742) apply pressure on tool until ball joint breaks loose from upper part of the front spindle (Illustration 6). Remove front spindle with the hub assembly attached, set aside.

11) Slowly release the floor jack. Once all pressure has been released, remove chain and front coil spring.

12) Remove nuts, washers and bolts fastening the lower control arm to frame and set assembly aside (Illustration 7).

13) Repeat steps 2 thru 12 on opposite side.

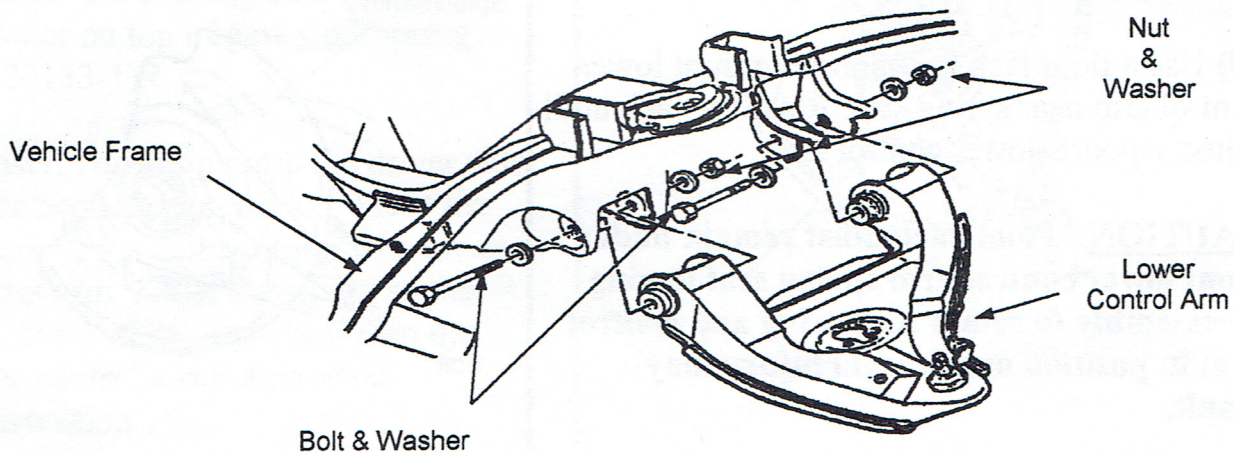
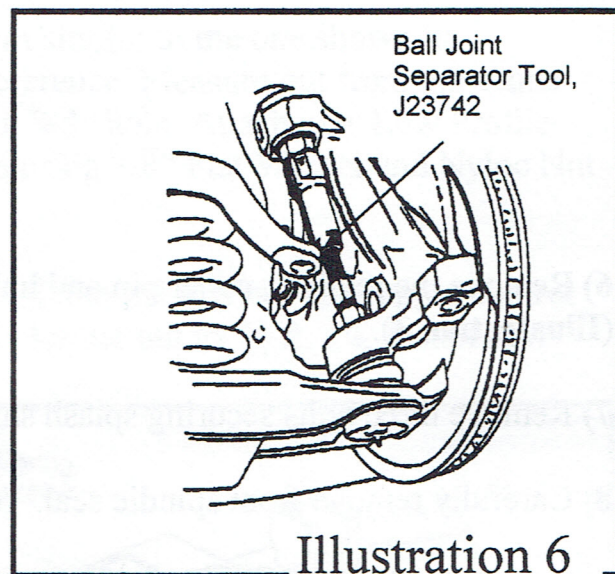
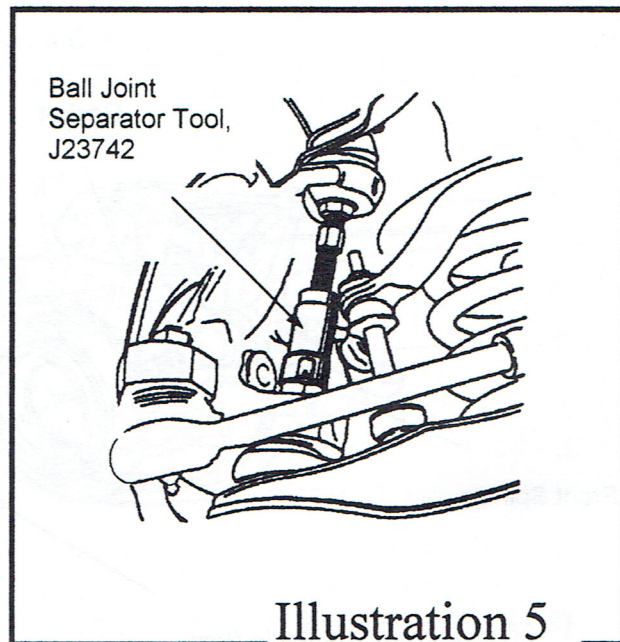
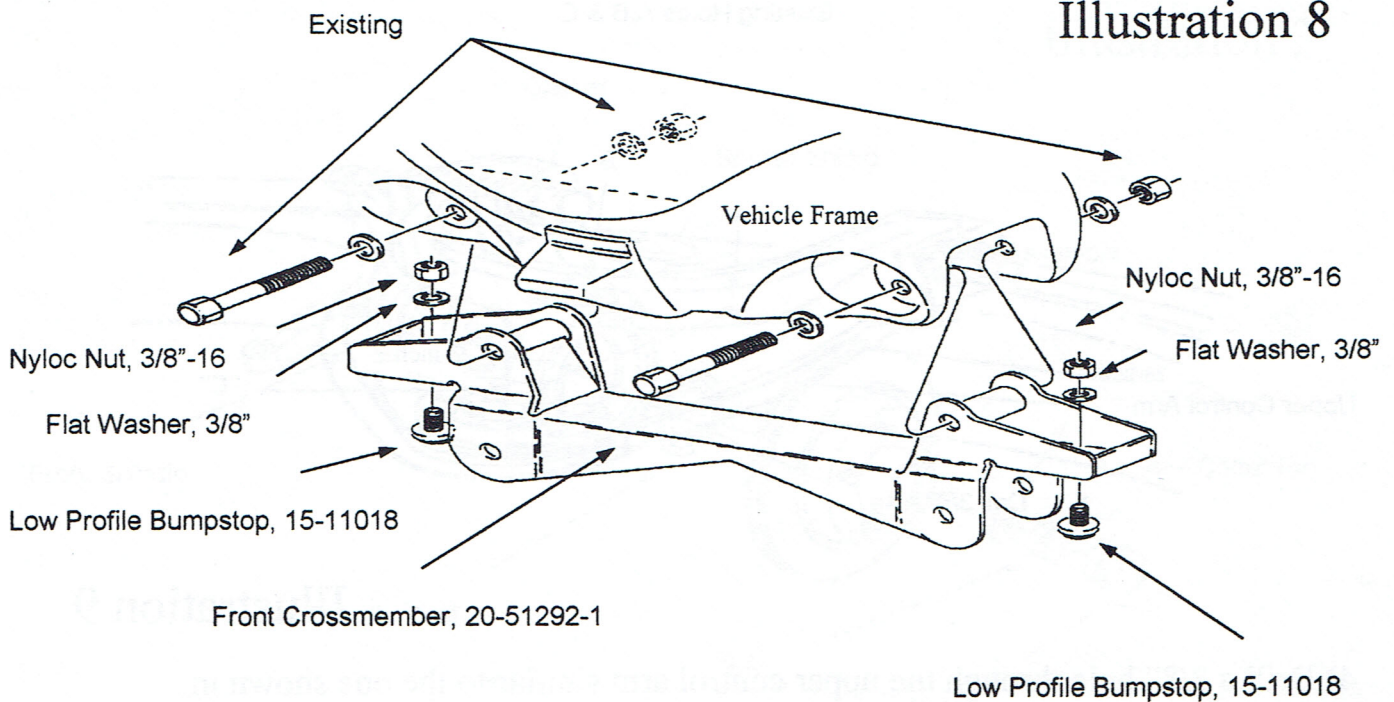

Illustration 7

Illustration 8



FRONT INSTALLATION

1) Install Front Crossmember (20-51292-1) into front lower control arm mounting position with existing hardware. Make sure the bolt heads are facing to the front of the vehicle (**Illustration 8**). Do not tighten hardware at this time.

NOTE: On some later model vehicles it may be necessary to grind existing lower control arm pockets for clearance.

2) Install both of the new Low Profile Bumpstops (15-11018) on front crossmember as shown in **Illustration 8**. Torque 3/8" nut to 35 ft. lbs.

3) Install Rear Crossmember (20-51292-2) into rear lower control arm mounting position using the existing hardware previously removed. Make sure that the bolt heads are facing to the front of the vehicle. Do not fasten at this time.

Existing Holes A,B & C

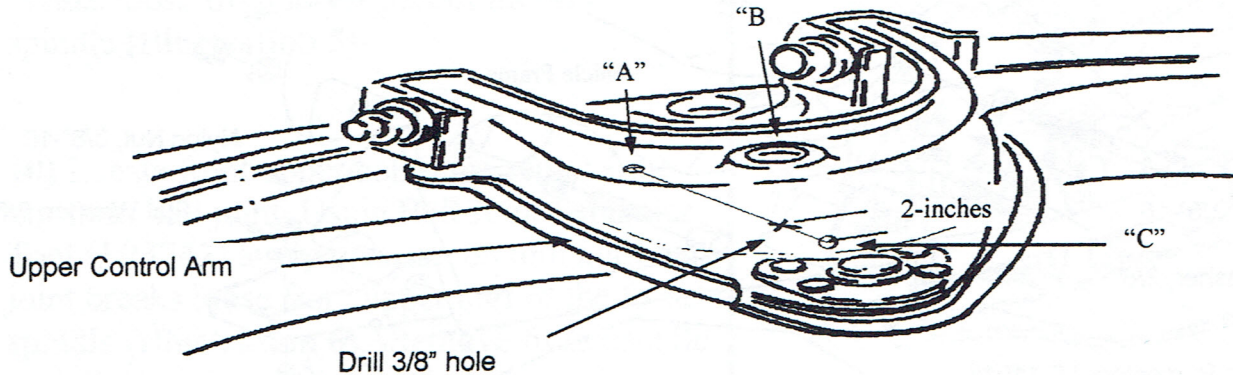

Illustration 9

4) Drill a 3/8" hole through the upper control arm similar to the one shown in **Illustration 9**. Use the three existing holes as reference. Measure out from the center of Hole "C" 2-inches towards Hole "A" and drill 3/8" hole. Attach new Low Profile Bumpstop to the underside of upper control arm using 3/8" Flat Washer and Nyloc Nut provided. Torque 3/8" nut to 35 ft. lbs.

5) Attach driver's side Front Spindle (20-51290-5D) to the driver's side upper control arm. Use castellated nut previously removed and torque nut to 74 ft. lbs. Install new cotter pin provided.

6) Attach driver's side lower control arm to front spindle. Use castellated nut previously removed. Torque nut to 94 ft. lbs.

7) Install the existing coil spring insulator on top of new Coil Spring (20-20153-1).

8) Insert coil spring into the driver side upper frame spring pocket. Place the bottom of the coil spring on the lower control arm. Align the spring so that it leaves one of the drain holes (in the lower control arm) uncovered (**Illustration 10**).

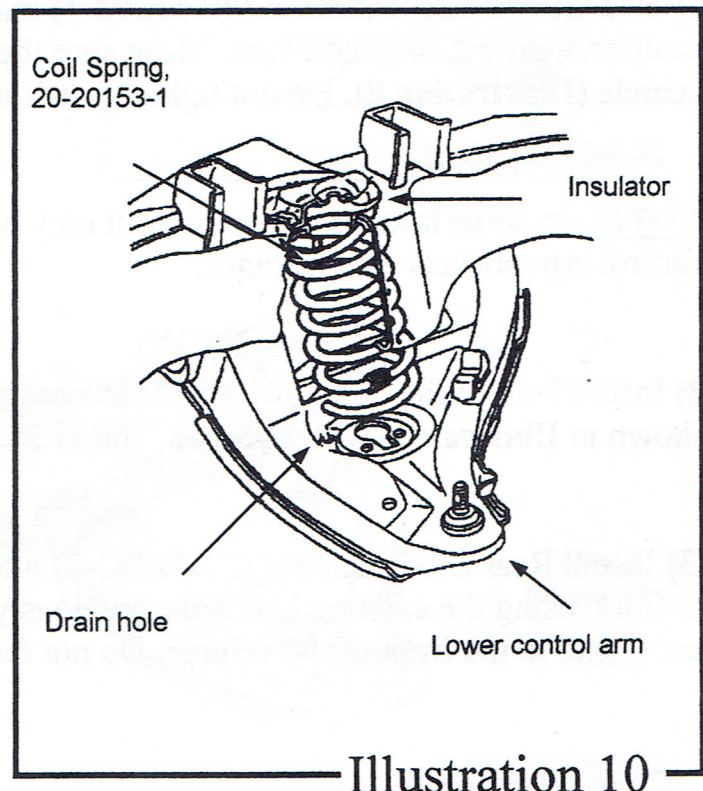
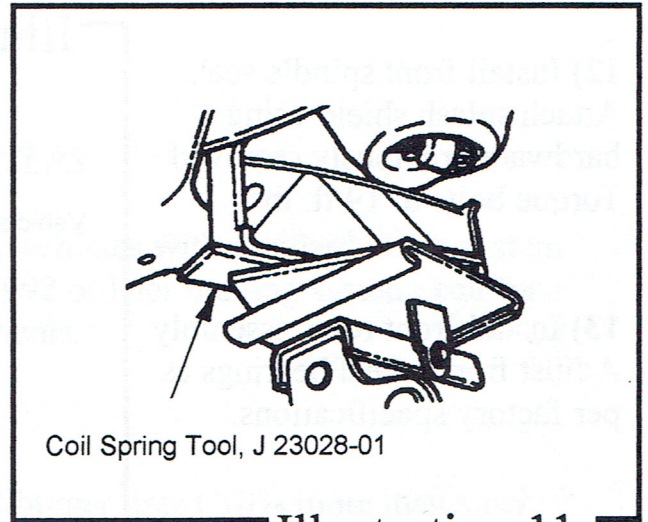

Illustration 10

9) Support the lower control arm with coil spring remover tool (J 23028-01) attached to a floor jack (**Illustration 11**).

10) Secure the coil spring to the lower control arm with a safety chain. Carefully raise the lower control arm into new crossmember pockets. Attach Strut Mount Bracket (20-51292-11) to rear crossmember and lower control arm. Make sure bolt head is installed with bolt head facing to the rear of the vehicle (**Illustration 12**).



Coil Spring Tool, J 23028-01

Illustration 11

NOTE: Do not torque lower control arm nuts until vehicle is at normal ride height. Lower the vehicle to the ground, torque 5/8" hardware to specification chart on last page.

11) Attach tie rods to front spindle. Fasten with nut previously removed. Torque nut to 46 ft. lbs.

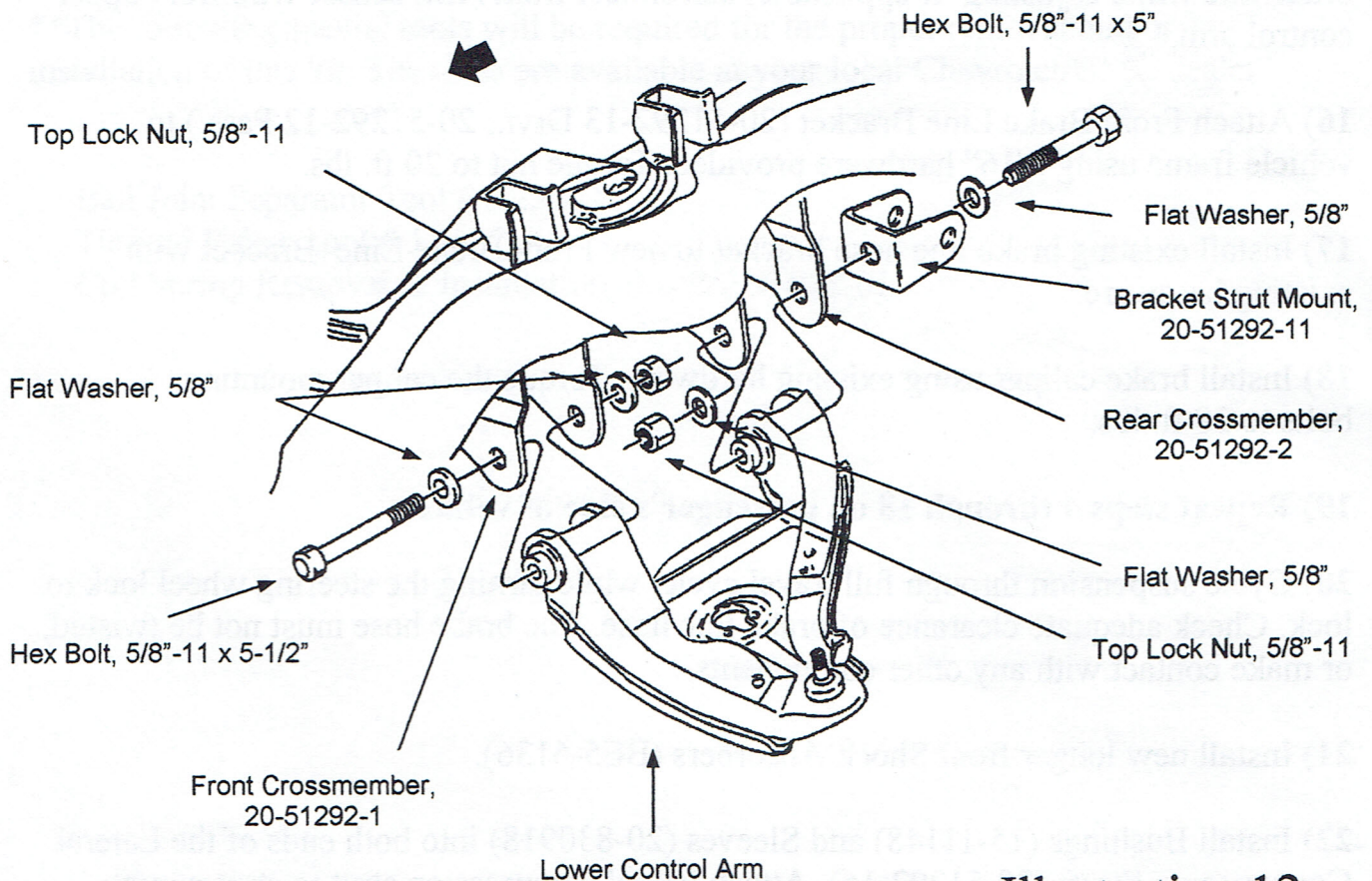
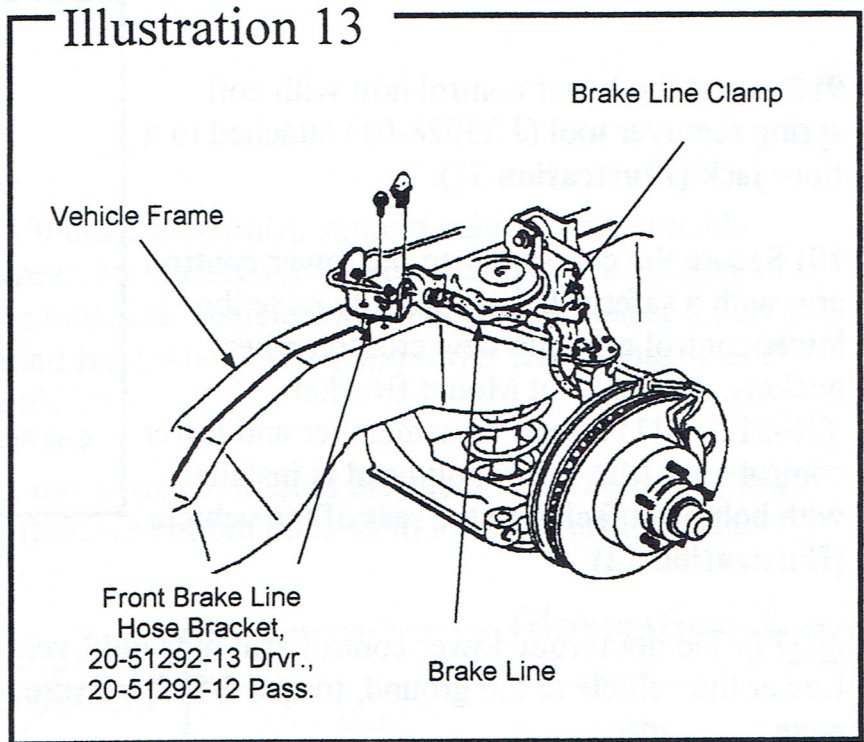

Illustration 12

12) Install front spindle seal. Attach splash shield using hardware previously removed. Torque bolts to 19 ft. lbs.

13) Install front rotor assembly. Adjust front wheel bearings as per factory specifications.

14) Disconnect driver's side brake line hose bracket from vehicle frame (**Illustration 13**).



15) Locate the brake line clamp bracket attached to the upper control arm. Loosen clamp around brake line so the brake line can be adjusted. Be careful not to damage brake line while adjusting. If applicable, disconnect front ABS sensor wire from upper control arm.

16) Attach Front Brake Line Bracket (20-51292-13 Drvr., 20-51292-12 Pass.) to vehicle frame using 5/16" hardware provided. Torque nut to 20 ft. lbs.

17) Install existing brake line hose bracket to new Front Brake Line Bracket with existing hardware.

18) Install brake caliper using existing hardware. Torque the caliper mounting bolts to 38 ft. lbs.

19) **Repeat steps 4 through 18 on passenger's side of vehicle.**

20) Cycle suspension through full travel cycle, while turning the steering wheel lock to lock. Check adequate clearance of brake line hose. The brake hose must not be twisted, or make contact with any other components.

21) Install new longer front Shock Absorbers (BE5-6136).

22) Install Bushings (15-11148) and Sleeves (20-830918) into both ends of the Lateral Compression Struts (20-51292-16). Attach lateral compression strut to strut mount

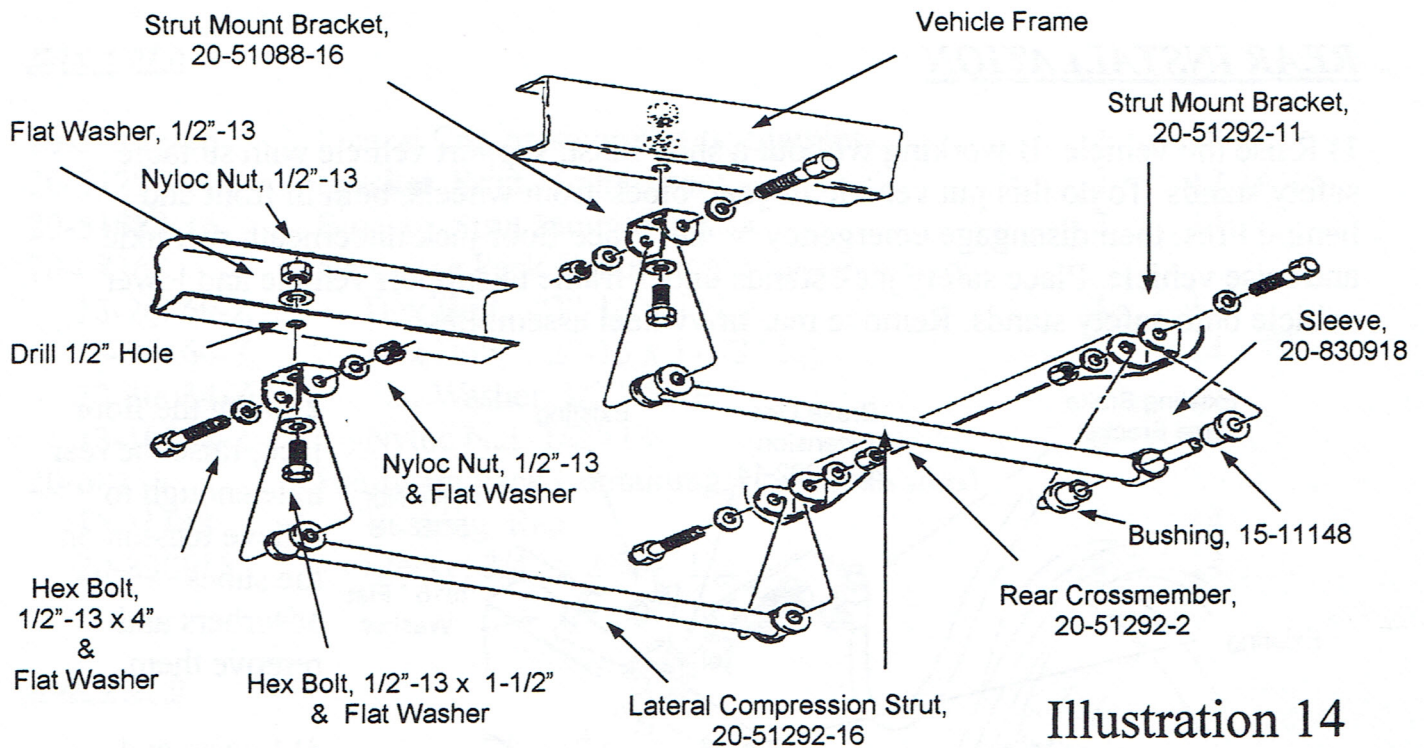

Illustration 14

bracket located on rear crossmember using hardware provided (**Illustration 14**). Do not tighten hardware at this time.

23) Attach Strut Mount Bracket (20-51088-16) to opposite end of compression strut. Rotate the compression strut assembly upward until bracket contacts the bottom of the frame rail. Using the bracket as a guide, mark and center punch the mounting hole locations. Drill 11/32" diameter hole at each of the marked locations. Install using the 3/8" self-tapping hardware provided.

24) Install front wheels and lower vehicle to the ground. Torque stock wheel lug nuts to 90-120 ft. lbs.

24) Once vehicle is at proper ride height torque lower control arm to frame nuts to 121 ft. lbs. Torque compression strut bracket 1/2" bolts to 90 ft. lbs.

25) Install existing sway bar end to each lower control arm using Sway Bar Extension (20-832855) and hardware provided (**Illustration 15**). Torque 1/2"-13 x 3" Button Head, (13-22743-Z) bolts to 66 ft. lbs.

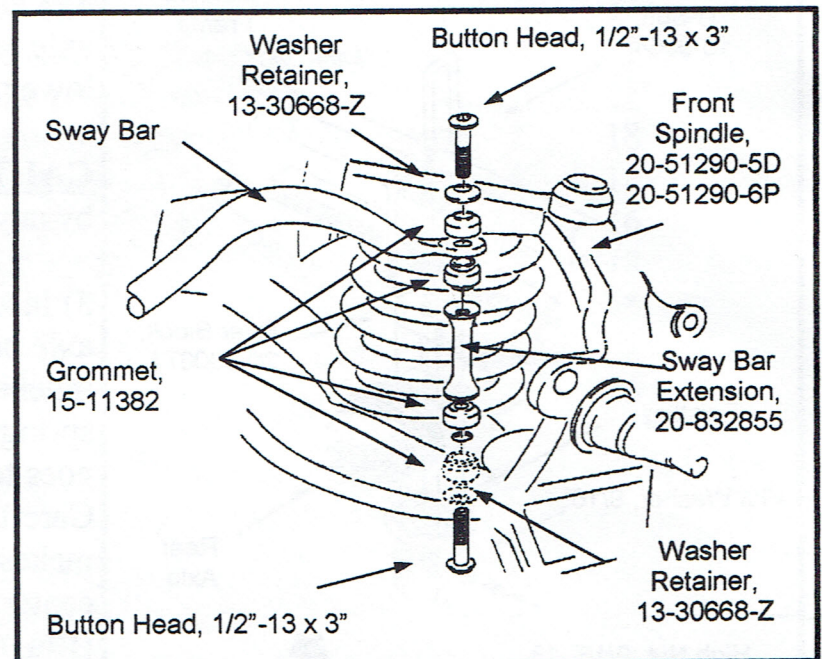
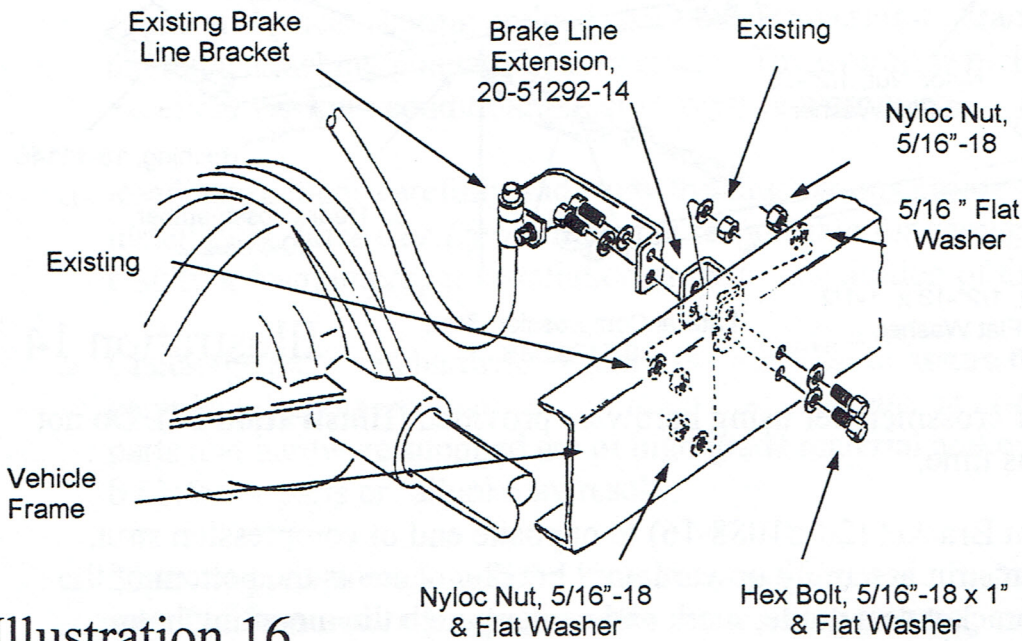

Illustration 15

REAR INSTALLATION

1) Raise the vehicle. If working without a shop hoist, support vehicle with suitable safety stands. To do this put vehicle in gear, block front wheels, both in front and behind tires, then disengage emergency brake. Place floor jack underneath rear axle and raise vehicle. Place safety jack stands under frame to support vehicle and lower vehicle onto safety stands. Remove rear tire/wheel assemblies.



2) With the floor jack, raise the rear axle enough to relieve tension on the shock absorbers and remove them.

3) Locate and disconnect existing brake line bracket attached to frame on the driver's side of vehicle (Illustration 16).

Illustration 16

4) Remove rear U-bolts attaching rear axle to driver side leaf spring. Carefully lower rear axle.

CAUTION: Do not allow axle to hang by any hoses or cables.

5) Insert new riser Block (20-830671) on axle pad. Make sure the pin in the block indexes into the hole of the axle housing spring pad. The short end of the block goes toward the front of the vehicle. Carefully raise rear axle until block makes contact with leaf spring. Make sure center bolt is aligned with hole in block (Illustration 17).

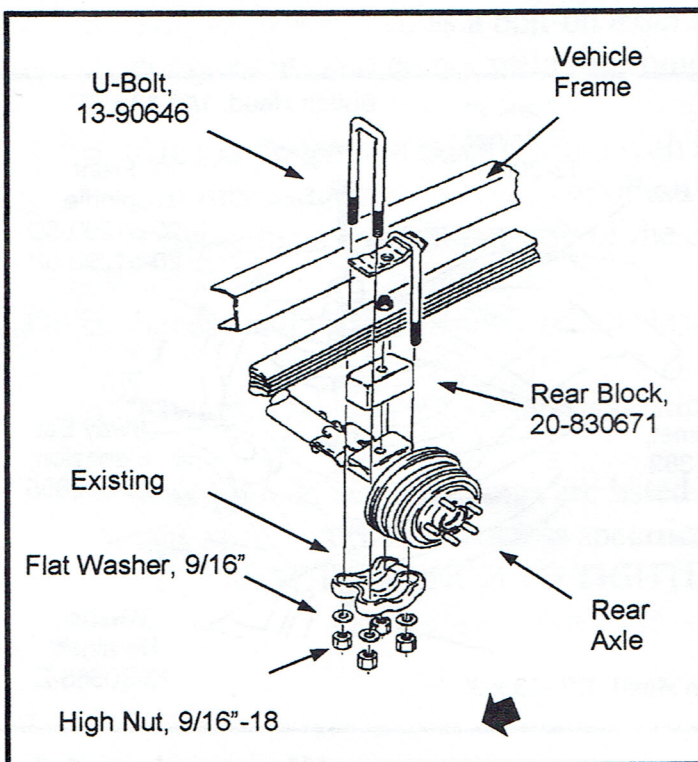

Illustration 17

6) Re-mount axle to spring using the new U-bolts, washers and nuts and existing spring plates. Torque U-bolts nuts to 85-100 ft. lbs.

7) Repeat steps 3 through 6 on passenger side.

7) Install new longer rear Shock Absorber (BE5-6137), using the existing hardware. Torque lower axle mount nuts to 52 ft. lbs. Attach shock to upper frame mount and torque to 13 ft. lbs.

8) Attach Rear Brake Line Extension (20-51292-14) to driver's inside frame rail. Use existing hardware. Attach original bracket to Extension using 5/16" hardware provided. Torque nuts to 20 ft. lbs (Illustration 16).

9) Remove existing rear bumpstop from the bottom of the frame rail (Illustration 18).

10) Assemble existing bumpstop to Rear Bumpstop Extension (20-51292-15) using the original hardware.

11) Install rear bumpstop assembly to the frame rail at the original bumpstop location, using the hardware provided. Torque 3/8" nuts to 30 ft. lbs.

12) Repeat steps 9 thru 11 on opposite side.

13) Install rear wheels and lower the vehicle. Torque stock wheel lug nuts to 90-120 ft. lbs.

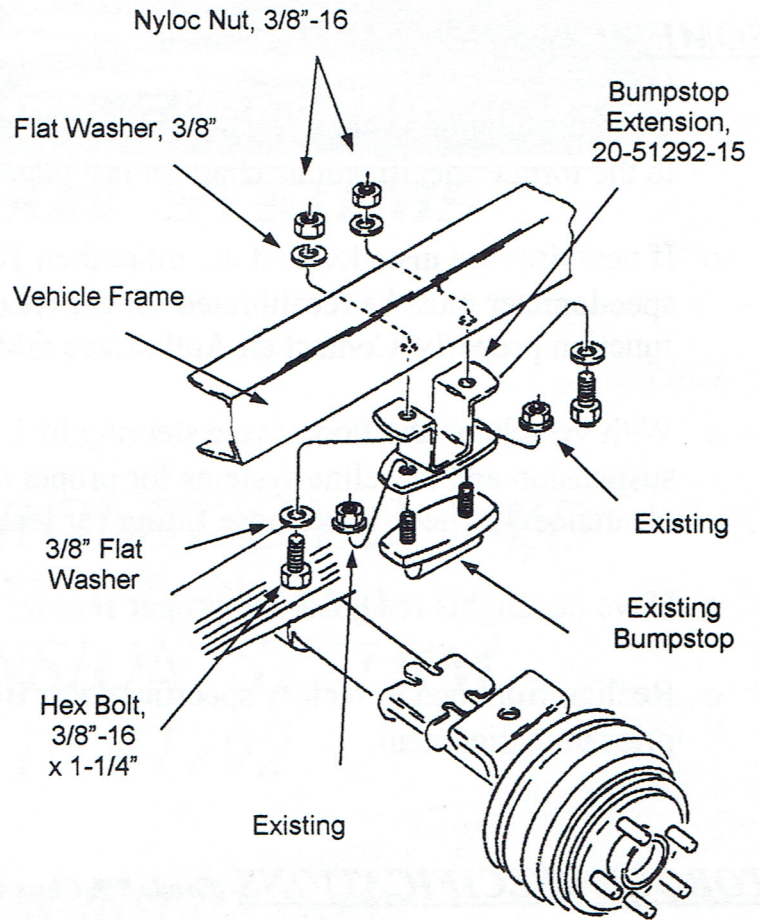

Illustration 18

SOME FINAL NOTES

- Once installation is complete, double check that all nuts and bolts are tight. Refer to the torque specifications chart on last page.
- If new tires are installed that are more than 10% taller than original tires, the speedometer must be recalibrated for the Rear Wheel Anti-Lock Brake System to function properly. Contact an Authorized GM dealer for details on recalibration.
- With vehicle on the floor, cycle steering lock to lock and inspect steering, suspension and driveline systems for proper operation, tightness and adequate clearance. Recheck brake/hose fitting for leaks. Be sure all hoses are long enough.
- Have headlights readjusted to proper setting.
- Realign front end to factory specifications. Be sure vehicle is at desired ride height prior to realignment.

TORQUE SPECIFICATIONS (Grade 8 & Class 10.9)

5/16" NUTS	20 ft. lbs.	M6	9 ft. lbs.
3/8" NUTS	35 ft. lbs.	M8	23 ft. lbs.
7/16" NUTS	60 ft. lbs.	M10	45 ft. lbs.
1/2" NUTS	90 ft. lbs.	M12	75 ft. lbs.
9/16" NUTS	160 ft. lbs.	M14	120 ft. lbs.
5/8" NUTS	175 ft. lbs.	M16	165 ft. lbs.

EXISTING TORQUE SPECIFICATIONS

FRONT ANCHOR PLATE TO KNUCKLE NUT	210 ft. lbs.
LOWER CONTROL ARM NUTS	121 ft. lbs.
TIE ROD NUTS	46 ft. lbs.
LOWER BALL JOINT NUTS	94 ft. lbs.
UPPER BALL JOINT NUTS	74 ft. lbs.
HUB AND BEARING NUT	133 ft. lbs.